

Operating Instructions & Parts Manual

Please read and save these instructions. Read carefully before attempting to assemble, install, operate or maintain the product described. Protect yourself and others by observing all safety information. Failure to comply with instructions could result in personal injury and/or property damage! Retain instructions for future reference.

Hydraulic Elevating Carts

CART-2000
&
CART-4000

Description

Portable ergonomic elevating carts minimize worker bending and lifting. Materials can be easily loaded onto platform of cart, lowered to safe transporting height, and raised to unload at destination. Moves easily on four polyurethane caster; two swivel with brake and two rigid. All models feature a down speed control valve, internal hydraulic velocity fuse in each cylinder and an exclusive automatic two-speed manual hydraulic foot pump. All steel construction. Powder coated red finish. Failure to follow the proper operating instructions could result in injury.

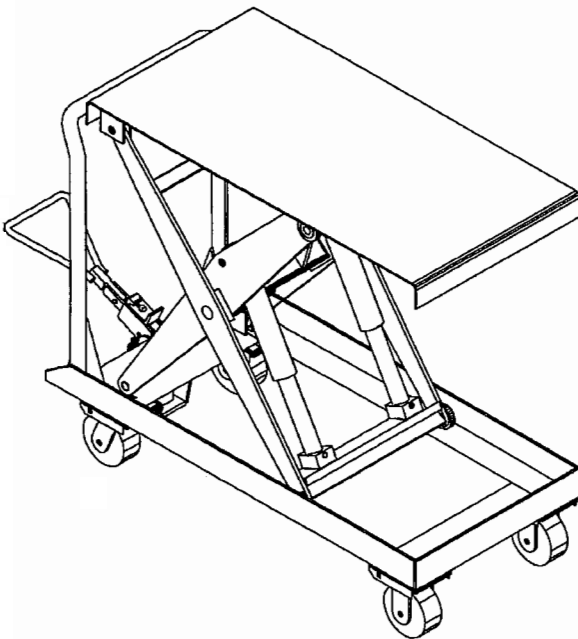

After receiving a hydraulic elevating cart, visually inspect the frame components and hydraulic unit for damage. If damage is evident, notify delivering carrier immediately and file necessary claims.

General Safety Information

1. Not a personnel lift. Keep clear when operating.
2. Never go under platform if there is weight on the unit.
3. Remove weight before working on unit.
4. Use only maintenance parts supplied or approved by the manufacturer.
5. Do not change pressure relief valve setting.
6. Do not clamp cylinder in a vise as you may distort barrel.
7. Never operate lift unless you are watching it.
8. Load lift as uniformly as possible.
9. Consult factory for uneven loading.
10. Do not continue to pump if unit is not raising.
11. Relieve system pressure by slowly operating pressure release mechanism.
12. Consult factory if any modifications are going to be made.
13. Do not use brake fluids or jack oils. Use AW-32 or hydraulic oils.

Assembly

TOOLS REQUIRED: (2) 9/16 in box end wrenches

After unpacking the cart locate the handle and the hardware to install it. Line up the mounting holes on the handle with the holes in the frame and install and tighten the bolts. Your cart is now ready for use.

Specifications and Dimensions

| Load Capacity | Platform Width | Platform Length | Lowered Height | Raised Height | Model Number | Weight (lbs.) |
|---------------|----------------|-----------------|----------------|---------------|--------------|---------------|
| 2,000 lbs. | 20" | 40" | 15" | 39" | CART-2000 | 336 lb. |
| 4,000 lb. | 24" | 47" | 15.5" | 40" | CART-4000 | 460 lb. |

Hydraulic Scissor Lift Carts

Foot Pump Operation

Your new lift equipment has been supplied with our exclusive 2-speed foot pump. The initial features of your pump includes a primary pressure relief, pressure compensated return flow control valve, and an integrated lowering valve. Replaceable bushings, valve components, and seals have been utilized in the construction of the pump in the event that replacements are necessary.

Stay clear of moving parts. The platform will rise as the foot pedal is pumped. Depressing the lowering valve will lower the table at a controlled rate of descent.

In the event the platform has been overloaded, the pressure relief will open because of excessive pressure buildup in the hydraulic system. Oil will bypass into the reservoir. NEVER change the pressure relief setting. DO NOT exceed the rated capacity of your lift equipment.

SPEED SELECTION FOR TWO-SPEED PUMPS

This pump offers two "speeds". The low speed setting produces low volume/high pressure. The high speed setting produces high volume/low pressure. The operator has the option of selecting the optimum pump speed for the application at hand. Pump speeds are selected by sliding the "lock collar" (See below) in or out. An occasional drop of oil will keep the collar working freely.

AIR BLEED PROCEDURE

Whether your pump is a new installation, or has been recently serviced, air has likely entered the hydraulic system. The design of this pump includes an "air bleed screw"

which will aid in the removal of unwanted air from the foot pump area of hydraulic system. Use the following steps to remove this air from the system.

1. Check all fittings to be sure they are tight. Ensure that the oil is filled to within 1" of the top of the reservoir when the lift is in the fully lowered position.
2. Locate the "air bleed screw" (see figure 3) and loosen approximately 1/2 turn counterclockwise. As soon as you have loosened the screw, slowly depress the foot pedal. This will force the air out of the pump chamber. Before you let the pump pedal return to the "up" or "home" position, tighten the air bleed screw. This will prevent air from reentering the pump chamber. Repeat the above procedure until the pump chamber is completely filled with oil and a "spongy" feel is no longer present. If the air bleeding procedure has been successful, the feel of the pump pedal will be firm and the complete stroke of the pump will produce fluid flow.

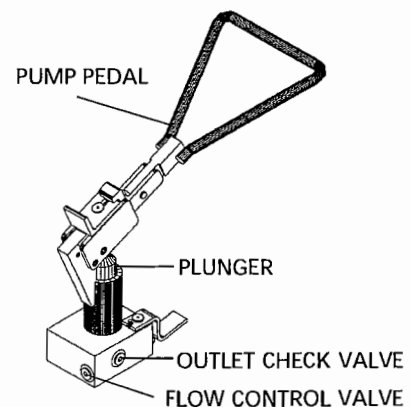
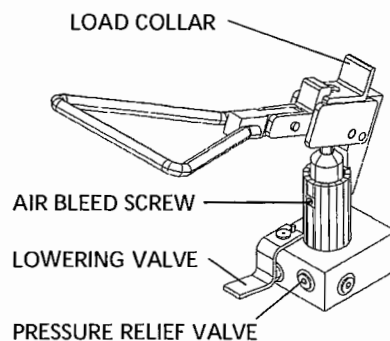

Hydraulic foot pump

Maintenance

All bushings and bearings are of the pre-lubricated type and will last for a long period of time without additional lubrication. To increase bearing life, it is recommended that a few drops of light machine oil be applied at each pivot point every 6 to 12 months.

DAILY

Visually check and do not use if any of the following are visible:

1. Oil Leaks.
2. Structural deformation of legs or frame.
3. Unusual noise or binding
4. Check casters for proper operation.

MONTHLY

1. Check for oil leaks.
2. Check clevis and pivot points for wear.
3. Check rollers for looseness and wear.
4. Check for unusual noise.
5. Make sure all warning labels are in place and in good condition.
6. Clean off dirt and debris.

Maintenance procedures

YEARLY

Hydraulic oil should be changed at least once a year, or sooner if the oil darkens or becomes gritty. Flush reservoir before refilling. Presence of water is indicated if the oil turns milky. Recommended oil: AW-32 hydraulic fluid or equal.

All maintenance work must be performed by qualified personnel with training in the repair of electrical and hydraulic components.

NOTE: If hydraulic oil is milky white in color, water is in the hydraulic system. Change the hydraulic oil immediately.

TO FILL UNIT WITH OIL

1. Raise the platform and block the leg assembly in the fully raised position.
2. Remove the upper cylinder pin.
3. Loosen the set screw in the lowering rod linkage.
4. Release the lowering valve.
5. Collapse the cylinder rod back inside the cylinder.
6. Remove the oil fill plug.
7. With the cylinder horizontal, fill

with AW-32 grade hydraulic oil (or equivalent).

8. Reinstall the fill plug, and then reinstall the cylinder.

TO BLEED SYSTEM

1. Ensure platform is in lowered position.
2. Operate the lowering mechanism and pump the foot control several times slowly.

TO FILL WITH OIL LOW OIL CONDITION

1. Raise the unit as far as it will go.
2. Remove the oil fill plug.
3. Add oil 1 oz. at a time.
4. Pump the foot control.
5. Repeat steps 3 and 4 until the unit's maximum height is achieved.
6. Once the maximum height is reached, add 1 oz. of oil and reinstall the fill plug.

IF CART LEAKS DOWN

1. Completely lower the platform. By hand, grasp the deck at the hinge end of the leg assembly. Raise the deck as high as possible, then

carefully, while standing aside, allow the assembly to drop. This procedure draws oil through the load holding check valve and "washes" debris (if present) from the ball and seat of the device. It may be necessary to repeat this procedure a couple of times to remove all debris from the check valve thus, eliminating table drift.

2. Check the oil level in the pump assembly. The oil should be level with the bottom of the hole with the scissor legs in the lowered position. (Deck tilts up).

NOTE: If these steps fail to return the unit to service, contact supplier for further instructions.

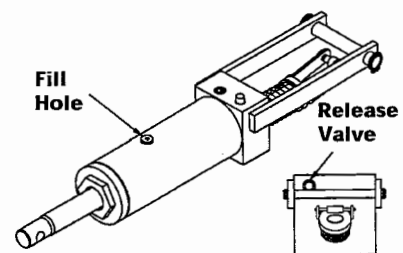
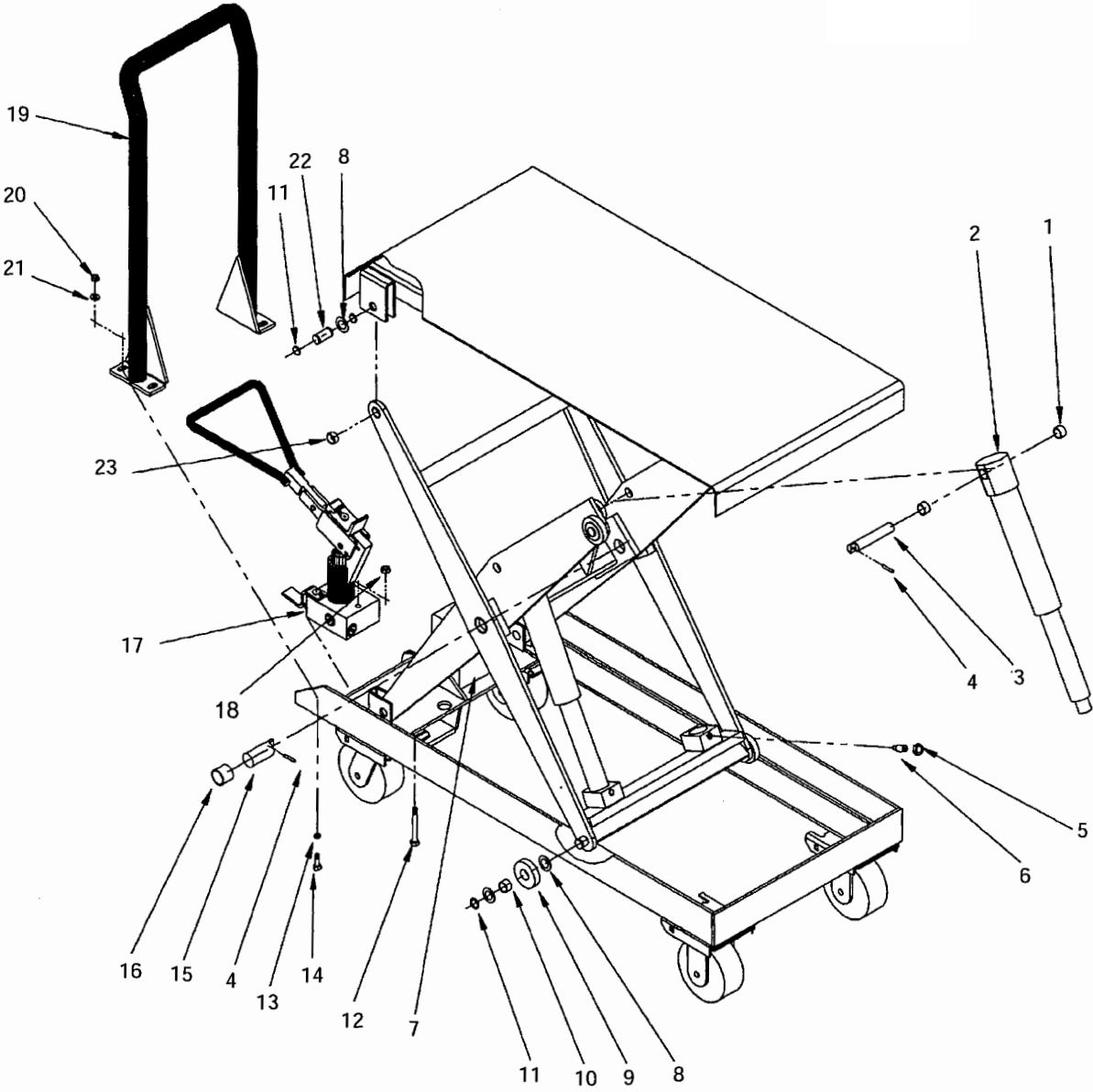

FIG. 1: CART-2000 exploded parts diagram



CART-2000 bill of materials

| Reference Number | Description | Engineer Number | Part Number | Quantity |
|------------------|--|-----------------|-------------|----------|
| 1 | Bearing Sleeve 3/4" D x 3/4" lg. | 01-111-009 | C2001-2 | 4 |
| 2 | Cylinder, Hydraulic 1-1/2" D x 7" STK | 01-021-030 | C2002-2 | 2 |
| 3 | Pin, Cylinder Pivot 3/4" D x 4-1/4" lg. | 01-112-010 | C2003-2 | 2 |
| 4 | Pin, Spring 3/16" D x 1-1/8" lg. | 64134 | C2004-2 | 4 |
| 5 | Nut, Jam 1/2"-13 unc | 36209 | C2005-2 | 2 |
| 6 | Bolt, Cylinder Retaining | 01-118-002 | C2006-2 | 2 |
| 7 | Reservoir, Plastic Tank | 01-023-003 | C2007-2 | 1 |
| 8 | Shim, Machine Busing 3/4" ID x 18 ga. | 33424 | C2008-2 | 12 |
| 9 | Roller, 2-1/4" D x 1/2" W | 01-027-002 | C2009-2 | 4 |
| 10 | Bearing, Sleeve 3/4" D x 1/2" lg. | 01-111-008 | C2010-2 | 4 |
| 11 | Retainer Snap Ring, External for 3/4" D Pin | 68015 | C2011-2 | 12 |
| 12 | Screw, HHCS 3/8"-16 unc x 3" lg. | 11115 | C2012-2 | 2 |
| 13 | Screw, HHCS 5/16" -18 unc x 1" lg. | 11055 | C2013-2 | 4 |
| 14 | Washer, Lock 5/16" nom ID | 33620 | C2014-2 | 4 |
| 15 | Pin, Scissor Leg Pivot 1-1/8" D x 2-11/16" lg. | 01-112-008 | C2015-2 | 2 |
| 16 | Bearing Sleeve 1-1/8" D x 1" lg. | 01-111-005 | C2016-2 | 2 |
| 17 | Pump, Manual Foot 2-speed | 01-640-005 | C2017-2 | 1 |
| 18 | Nut, Hex Nylock 3/8"-16 UNC | 37024 | C2018-2 | 2 |
| 19 | Handle | 01-525-001 | C2019-2 | 1 |
| 20 | Nut, hex Nylock 5/16"-18 UNC | 37021 | C2020-2 | 4 |
| 21 | Washer, Flat 5/16" non ID | 33006 | C2021-2 | 4 |
| 22 | Pin, Hinge 3/4" D x 1-7/16" lg. | 01-112-009 | C2022-2 | 4 |
| 23 | Bearing, Sleeve 3/4" D x 3/8" lg. | 01-111-004 | C2023-2 | 4 |
| 24 | Rigid Caster | 16-132-022 | C2024-2 | 2 |
| 25 | Swivel Caster | 16-132-053 | C2025-2 | 2 |

FIG. 2: CART-4000 exploded parts diagram

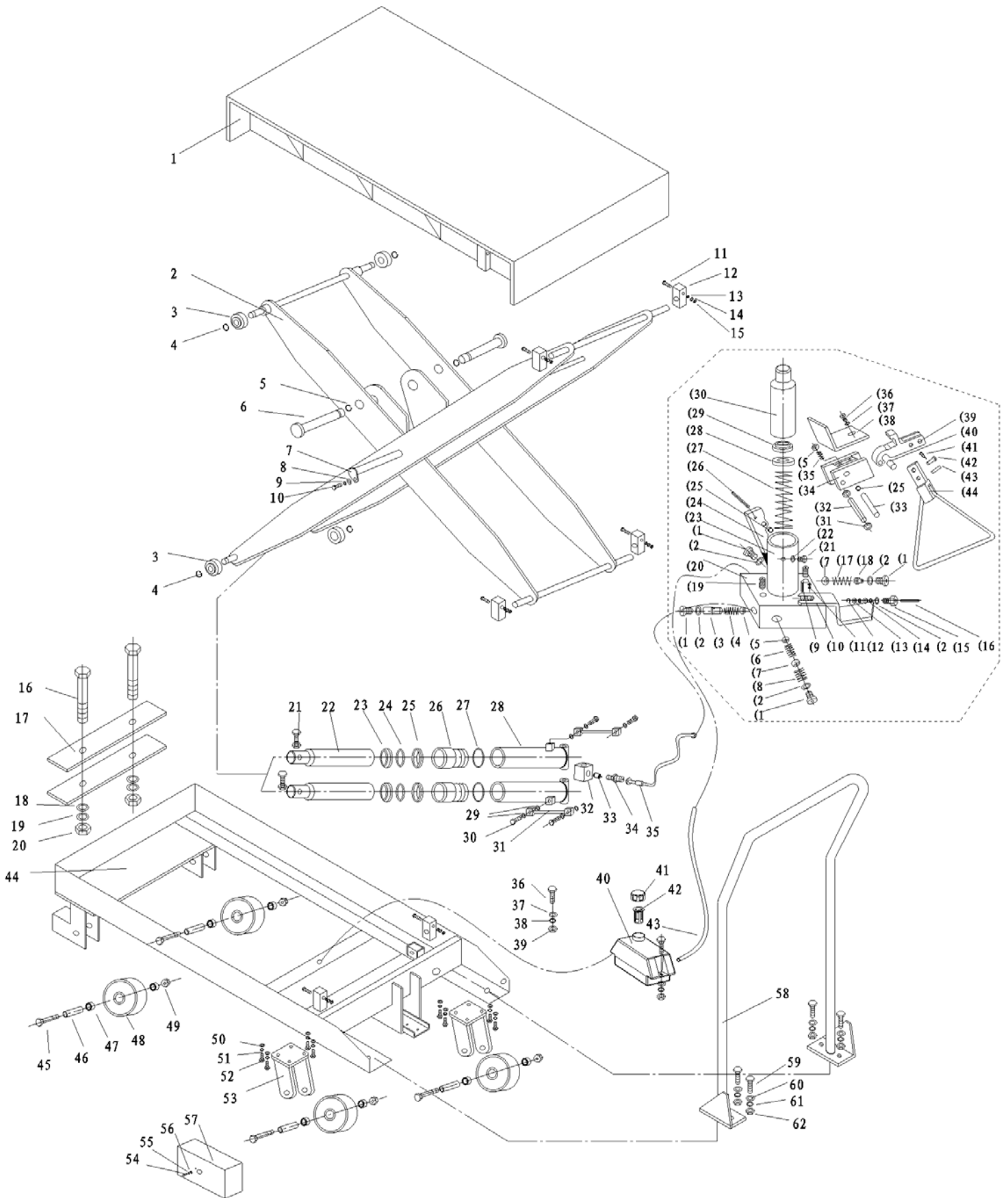

CART-4000 bill of materials

| No. | Descriptions | Q'ty | No. | Descriptions | Q'ty | No. | Descriptions | Q'ty |
|-----|-----------------|------|-----|-------------------------------|------|------|-------------------------------|------|
| 1 | Table | 1 | 37 | Flat Washer | 16 | (10) | Discharge Block | 2 |
| 2 | Link Assembly | 1 | 38 | Spring Washer | 16 | (11) | Hex Cap Screw | 1 |
| 3 | Roller Guide | 1 | 39 | Nut | 2 | (12) | C-Ring $\Phi 7$ | 1 |
| 4 | C-Ring | 4 | 40 | Oil Box | 4 | (13) | Flat Washer | 1 |
| 5 | C-Ring | 4 | 41 | Oil Box Cover | 4 | (14) | O-Ring | 1 |
| 6 | Shaft | 2 | 42 | Filter | 8 | (15) | Air Breather | 1 |
| 7 | Center Shaft | 1 | 43 | Oil Pipe | 4 | (16) | Top Rod | 1 |
| 8 | Flat Washer | 1 | 44 | Frame | 4 | (17) | Spring | 1 |
| 9 | Spring Washer | 1 | 45 | Hex Cap Bolt | 0 | (18) | Air Breather | 1 |
| 10 | Hex Cap Bolt | 1 | 46 | Shaft Cover | 1 | (19) | Fix Screw Post | 1 |
| 11 | Hex Cap Bolt | 4 | 47 | Separate Cover | 4 | (20) | Valve Block | 1 |
| 12 | Link Seat | 4 | 48 | Wheel | 4 | (21) | Hex Cap Screw PostM6 | 1 |
| 13 | Flat Washer | 4 | 49 | Nut | 4 | (22) | Washer | 1 |
| 14 | Spring Washer | 4 | 50 | Flat Washer | 4 | (23) | Cylinder | 1 |
| 15 | Hex Cap Nut | 4 | 51 | Spring Washer | 2 | (24) | Fixed Block | 1 |
| 16 | Hex Cap Bolt | 2 | 52 | Hex Hep Bolt | 2 | (25) | Bushing | 2 |
| 17 | Fix Block | 2 | 53 | Wheel Holder | 2 | (26) | Spring Pin $\Phi 6 \times 40$ | 1 |
| 18 | Flat Washer | 2 | 54 | Screw | 2 | (27) | Spring | 1 |
| 19 | Spring Washer | 2 | 55 | Spring Washer | 2 | (28) | UHS25 Oil Seal | 1 |
| 20 | Nut | 2 | 56 | Flat Washer | 2 | (29) | DH25 Dust Cover | 1 |
| 21 | Hex Cap Bolt | 2 | 57 | Wheel Protect Cover | 2 | (30) | Lift Piston | 1 |
| 22 | Piston Rod | 2 | 58 | Handle | 1 | (31) | Flat Washer | 2 |
| 23 | DH Dust Cover | 2 | 59 | Hex Cap Bolt | 4 | (32) | Shaft(1) | 1 |
| 24 | O-ring | 2 | 60 | Flat Washer | 4 | (33) | Shaft(2) | 1 |
| 25 | UHS Seal Kit | 1 | 61 | Spring Washer | 4 | (34) | Jiont Block | 1 |
| 26 | Top Nut | 1 | 62 | Nut | 4 | (35) | Spring | 1 |
| 27 | O-ring | 2 | | | | (36) | Screw Post | 1 |
| 28 | Cylinder Body | 2 | (1) | Air Breather M14 \times 1.5 | 4 | (37) | Flat Washer | 1 |
| 29 | Compose Washer | 4 | (2) | O-Ring $\Phi 16 \times 2.4$ | 5 | (38) | Block | 1 |
| 30 | Oil Pipe Tie-in | 4 | (3) | Lowering Valve | 1 | (39) | Pressure Block | 1 |
| 31 | Harden Oil Pipe | 2 | (4) | Spring | 1 | (40) | Pressure Guide | 1 |
| 32 | Fix Block | 1 | (5) | Steel Ball $\Phi 8$ | 2 | (41) | Lock Pin | 1 |
| 33 | Safe Valve | 1 | (6) | Spring | 1 | (42) | Shaft(3) | 1 |
| 34 | Tie-in | 1 | (7) | Steel Ball $\Phi 10$ | 2 | (43) | Shaft(4) | 1 |
| 35 | Oil Pipe | 1 | (8) | Spring | 1 | (44) | Foot Pedal | 1 |
| 36 | Hex Cap Bolt | 2 | (9) | Spring Pin $\Phi 5 \times 16$ | 1 | | | |

FIG. 3: Hydraulic foot pump exploded parts diagram

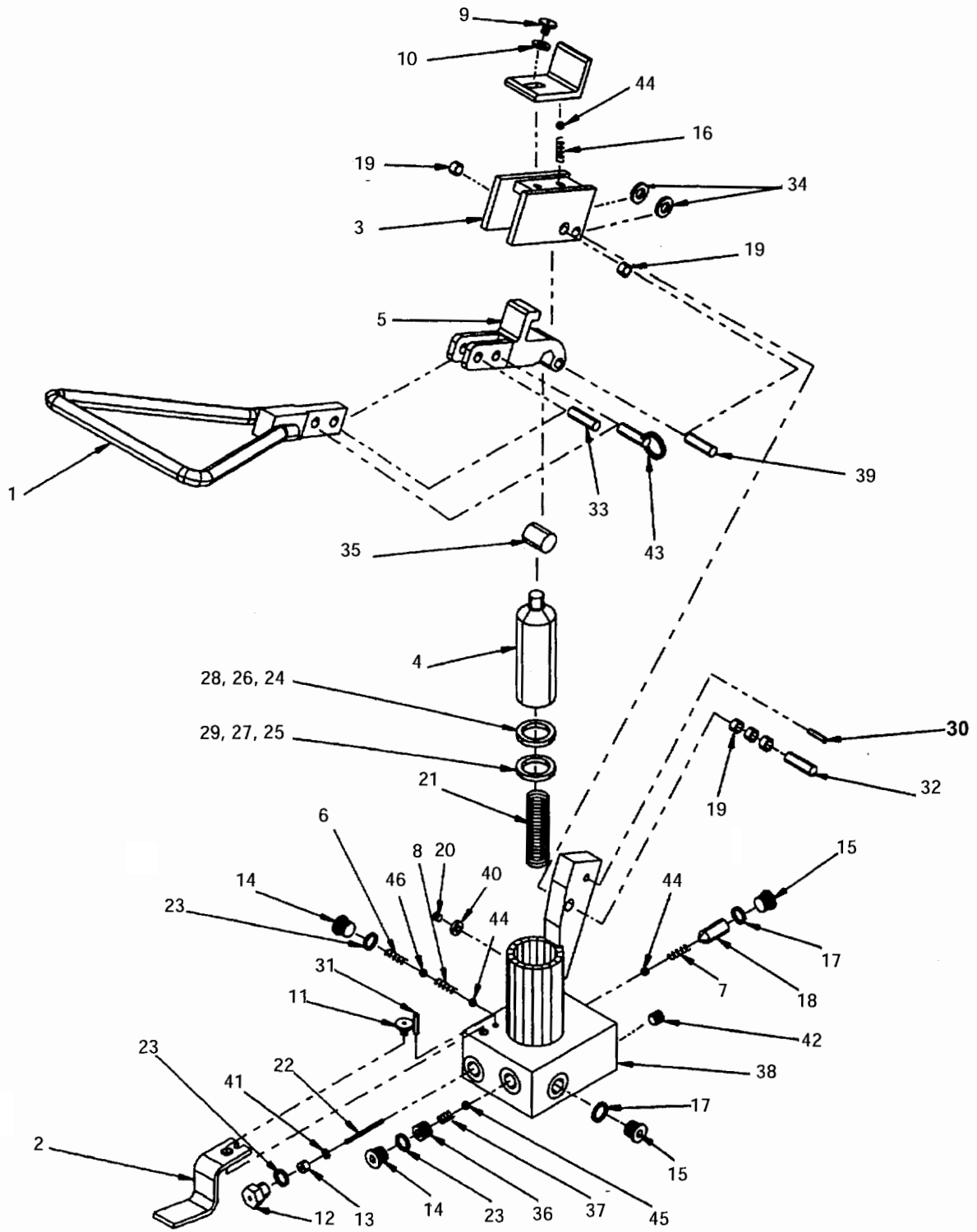

Hydraulic foot pump bill of materials

| Reference Number | Description | Engineer Number | Part Number | Quantity |
|------------------|--|-----------------|-------------|----------|
| 1 | Assembly, Foot Pedal, Double Speed | n/a | VI081601 | 1 |
| 2 | Release Lever | n/a | VI081604 | 1 |
| 3 | Lever, First Link | n/a | VI081607 | 1 |
| 4 | Assembly Pump Plunger | n/a | VI081605 | 1 |
| 5 | Lever Second Link | n/a | VI081609 | 1 |
| 6 | Outlet Check Spring (7/16" Steel Ball) | n/a | VI081610 | 1 |
| 7 | Release Check Spring | n/a | VI081611 | 1 |
| 8 | Inlet Check Spring (5/16" Steel Ball) | n/a | VI081612 | 1 |
| 9 | Guide Shoulder Screw | n/a | VI081613 | 1 |
| 10 | Guide Shoulder Screw Washer | n/a | VI081614 | 1 |
| 11 | Release Lever Shoulder Screw | n/a | VI081615 | 1 |
| 12 | Fitting O-Ring Plug | n/a | VI081616 | 1 |
| 13 | Release Rod U-Cup Seal | n/a | VI081617 | 1 |
| 14 | Fitting O-Ring Plug | n/a | VI081618 | 2 |
| 15 | Dirt Plug | n/a | VI081619 | 2 |
| 16 | Detent Latch Spring | n/a | VI081620 | 1 |
| 17 | Dirt Plug Washer | n/a | VI081621 | 2 |
| 18 | Pressure Compensated Flow Control Valve | n/a | VI081622 | 1 |
| 19 | Sleeve Sintered Bronze Bearing | n/a | VI081623 | 5 |
| 20 | Hexagon Socket Head Cap Screw | n/a | VI081624 | 1 |
| 21 | Piston Return Spring | n/a | VI081625 | 1 |
| 22 | Release Pin | n/a | VI081627 | 1 |
| 23 | O-Ring | n/a | VI081628 | 3 |
| 24 | Piston Wiper Seal (1.25) | n/a | VI081629 | 1 |
| 25 | Piston U-Cup Seal (1.25) | n/a | VI081630 | 1 |
| 26 | Piston Wiper Seal (1.00) | n/a | VI081655 | 1 |
| 27 | Piston U-Cup Seal (1.00) | n/a | VI081656 | 1 |
| 28 | Piston Wiper Seal (1.375) | n/a | VI081660 | 1 |
| 29 | Piston U-Cup Seal (1.375) | n/a | VI081661 | 1 |
| 30 | Spring Pin (0.25 x 1.5 Ig.) | n/a | VI081631 | 1 |
| 31 | Spring Pin (0.188 x 0.75 Ig.) | n/a | VI081632 | 1 |
| 32 | Round Head Groove Pin (0.375 x 1.50 Ig.) | n/a | VI081633 | 1 |
| 33 | Round Head Groove Pin (0.375 x 1 Ig.) | n/a | VI081634 | 1 |
| 34 | Round Head Groove Pin Washer | n/a | VI081635 | 2 |
| 35 | Lever (Second Link) Roller | n/a | VI081636 | 1 |
| 36 | Ritting Pressure Adjustment Plug | n/a | VI081641 | 1 |
| 37 | Pressure Relief Spring | n/a | VI081642 | 1 |
| 38 | Subassembly, Foot Pump Base | n/a | VI081644 | 1 |
| 39 | Ground Dowell Pin (0.375 x 1.5 Ig.) | n/a | VI081646 | 1 |
| 40 | Socket Head Screw Sealing Washer | n/a | VI081647 | 1 |
| 41 | Release Pin Seal Retaining Ring | n/a | VI081648 | 1 |
| 42 | Assembly Hole Plug | n/a | VI081651 | 1 |
| 43 | Detent Pin | n/a | VI081662 | 1 |
| 44 | 5/16" Steel Chrome Ball | n/a | n/a | 1 |
| 45 | 3/8" Steel Chrome Ball | n/a | n/a | 1 |
| 46 | 7/16" Steel Chrome Ball | n/a | n/a | 1 |
| 47 | Seal Kit | 01-140-014 | CRT2000-SK | 1 |
| 48 | Foot Pump Assembly | 01-136-442 | CRT2000-FPA | 1 |

Troubleshooting guide

| Symptom | Possible Cause(s) | Corrective Action |
|--|--|--|
| 1. Deck does not raise | a. Excessive load | a. Remove part of the load |
| | b. Oil is low | b. Fill oil to within one inch of the top of the reservoir. |
| | c. Pinched hose | c. Connect as necessary |
| | d. Relief valve set too low | d. Increase only as necessary |
| 2. Foot pedal goes down hard but deck does not raise | a. Particle of dirt under the pressure relief | a. Lower deck - disassemble, clean and reassemble pressure relief * |
| | b. Particle of dirt under inlet check | b. Lower deck - disassemble, clean and reassemble inlet check valve* |
| 3. Unit will pump up only under no load or when rapidly stroked, or pedal will stroke with out pumping | a. Pump is air locked | a. Bleed air from system |
| | b. Inlet check valve has foreign material on seat | b. Remove and clean inlet ball and seat* |
| | c. Relief setting is out of adjustment | c. Adjust relief setting higher |
| | d. Foreign material on relief valve seat | d. See 2-2 |
| 4. Platform raises when the pump is stroked but lowers on return stroke | a. Outlet check is leaking | a. Clean foreign material from ball and seat |
| 5. Deck raises but takes too much effort | a. Change pump displacement speed | a. Slide locking collar back |
| 6. Deck raises but is too slow | a. Change pump displacement speed | a. Slide locking collar forward |
| | b. Intake filter clogged | b. Lower deck - drain reservoir, clean and flush debris, refill with clean oil |
| | c. Foreign material stuck under pressure relief valve or under inlet check valve | c. Lower deck - disassemble, clean and reassemble pressure relief* |

* Refer to exploded view on page 14

Troubleshooting guide (continued from p. 8)

| Symptom | Possible Cause(s) | Corrective Action |
|------------------------------------|---|--|
| 7. Spongy or jerky operation | a. Check for foreign material stuck in the deck or fame rails | a. Correct as necessary |
| | b. Oil is low | b. Fill oil to within one inch of the top of the reservoir |
| | c. Air in hydraulic system | c. See 3-3 |
| 8. Deck lowers too slowly | a. Pinched hose | a. Correct as necessary |
| | b. Intake filter clogged | b. Fill oil to within one inch of the top of the reservoir |
| | c. Foreign material lodged in velocity fuse | c. Lower deck - disassemble, clean and reassemble* |
| | d. Foreign material lodged in pressure compensated flow control valve | d. Lower deck - disassemble, clean and reassemble* |
| 9. Deck lowers too fast | a. Foreign material lodged in pressure compensated flow control valve | a. Lower deck - disassembled, clean and reassemble pressure relief* |
| 10. Deck raises but does not lower | a. Foreign material lodged n pressure compensated flow control valve | a. Lower deck - disassemble, clean and reassemble pressure relief* |
| | b. Release pin bent or missing | b. Replace as necessary |
| | c. Foreign objects blocking roller travel | c. Connect as necessary |
| | d. Velocity fuse is locked | d. Remove air from hydraulic system, to unlock, repressurize system (refer to hydraulic section in manual) |

* Refer to exploded view on page 14

LIMITED WARRANTY

90 DAY LIMITED WARRANTY. The manufacturer warrants for the original purchaser against defects in materials and workmanship under normal use 90 days after date of purchase. Any part which is determined by the manufacturer to be defective in material or workmanship and returned to the factory, shipping costs prepaid, will be, as the exclusive remedy, repaired or replaced at our option. Labor costs for warranty repairs and/or modifications are not covered unless done at manufacturer's facilities. Any modifications performed without written approval of the manufacturer may void warranty. This limited warranty gives purchaser specific legal rights which vary from state to state.

LIMITATION OF LIABILITY. To the extent allowable under applicable law, the manufacturer's liability for consequential and incidental damages is expressly disclaimed. The manufacturer's liability in any event is limited to, and shall not exceed, the purchase price paid. Misuse or modification may void warranty.

WARRANTY DISCLAIMER. Our company has made a diligent effort to illustrate and describe the products shown accurately; however, such illustrations and descriptions are for the sole purpose of identification, and do not express or imply a warranty that the products are merchantable, or fit for a particular purpose, or that the products will necessarily conform to the illustrations or descriptions.

The provisions of the warranty shall be construed and enforced in accordance with the UNIFORM COMMERCIAL CODE and laws as enacted in the State of Indiana.

DISPOSITION. Our company will make a good faith effort for prompt correction or other adjustment with respect to any product which proves to be defective within the Limited Warranty. Warranty claims must be made in writing within said year.

LIMITED WARRANTY

Vestil Manufacturing Corporation (“Vestil”) warrants this product to be free of defects in material and workmanship during the warranty period. *Our warranty obligation is to provide a replacement for a defective original part if the part is covered by the warranty, after we receive a proper request from the warrantee (you) for warranty service.*

Who may request service?

Only a warrantee may request service. *You are a warrantee if you purchased the product from Vestil or from an authorized distributor AND Vestil has been fully paid.*

What is an “original part”?

An original part is a part used to make the product as shipped to the warrantee.

What is a “proper request”?

A request for warranty service is proper if Vestil receives: 1) a photocopy of the Customer Invoice that displays the shipping date; AND 2) a written request for warranty service including your name and phone number. Send requests by any of the following methods:

Mail
Vestil Manufacturing Corporation
2999 North Wayne Street, PO Box 507
Angola, IN 46703

Fax
(260) 665-1339
Phone
(260) 665-7586

Email
sales@vestil.com

In the written request, list the parts believed to be defective and include the address where replacements should be delivered.

What is covered under the warranty?

After Vestil receives your request for warranty service, an authorized representative will contact you to determine whether your claim is covered by the warranty. Before providing warranty service, Vestil may require you to send the entire product, or just the defective part or parts, to its facility in Angola, IN. The warranty covers defects in the following *original* dynamic components: motors, hydraulic pumps, electronic controllers, switches and cylinders. It also covers defects in *original* parts that wear under normal usage conditions (“wearing parts”): bearings, hoses, wheels, seals, brushes, batteries, and the battery charger.

How long is the warranty period?

The warranty period for original components is 90 days. The warranty period begins on the date when Vestil ships the product to the warrantee. If the product was purchased from an authorized distributor, the period begins when the distributor ships the product. Vestil may extend the warranty period for products shipped from authorized distributors by *up to 30 days* to account for shipping time.

If a defective part is covered by the warranty, what will Vestil do to correct the problem?

Vestil will provide an appropriate replacement for any *covered* part. An authorized representative of Vestil will contact you to discuss your claim.

What is not covered by the warranty?

1. Labor;
2. Freight;
3. Occurrence of any of the following, which automatically voids the warranty:
 - Product misuse;
 - Negligent operation or repair;
 - Corrosion or use in corrosive environments;
 - Inadequate or improper maintenance;
 - Damage sustained during shipping;
 - Collisions or other incidental contacts causing damage to the product;
 - Unauthorized modifications: DO NOT modify the product IN ANY WAY without first receiving written authorization from Vestil. Modification(s) might make the product unsafe to use or might cause excessive and/or abnormal wear.

Do any other warranties apply to the product?

Vestil Manufacturing Corp. makes no other express warranties. All implied warranties are disclaimed to the extent allowed by law. Any implied warranty not disclaimed is limited in scope to the terms of this Limited Warranty.

